

# Eclipse ThermJet

## Burners

Model TJ0300

Version 2

Parameter	Burner Velocity		Model TJ0300
Maximum Input Btu/h (kW)	Medium & High Velocity		3,000,000 (879)
Minimum Input, On-Ratio Btu/h (kW)	Medium & High Velocity		300,000 (88)
Minimum Input, Fixed Air Btu/h (kW)	Medium & High Velocity		60,000 (18)
Gas Inlet Pressure Required "w.c. (mbar) Fuel Pressure at Gas Inlet (Tap "B" - see page 3)	High Velocity	Natural Gas	12.5 (31.0)
		Propane	12.7 (32.0)
		Butane	12.2 (30.0)
	Medium Velocity	Natural Gas	6.0 (15.0)
		Propane	6.8 (17.0)
		Butane	6.0 (15.0)
Air Inlet Pressure Required "w.c. (mbar) 15% Excess Air at Maximum Input (Tap "A" - see page 3)	High Velocity	Natural Gas	15.0 (38.0)
		Propane	15.0 (38.0)
		Butane	15.0 (38.0)
	Medium Velocity	Natural Gas	8.5 (21.0)
		Propane	8.5 (21.0)
		Butane	8.5 (21.0)
High Fire Flame Length Inches (mm) (Measured from End of Combustor)	High Velocity	Natural Gas	50 (1270)
		Propane	55 (1400)
		Butane	55 (1400)
	Medium Velocity	Natural Gas	64 (1630)
		Propane	66 (1675)
		Butane	68 (1730)
Maximum Flame Velocity ft/s (m/s) 15% Excess Air at Maximum Input	High Velocity		550 (168)
	Medium Velocity		300 (91)
Maximum Combustion Air Temperature	300°F (149°C). For higher temperatures, use TJPCA (Data 206)		
Flame Detection	UV scanners can be used with all combustors.		
Fuel	Natural gas, propane or butane. For any other mixed gas, contact Eclipse for orifice sizing.		
Approvals	 AN30		

- All information is based on laboratory testing in neutral (0.0" w.c.) pressure chamber. Different chamber size and conditions may affect the data.
- All information is based on standard combustor design. Changes in combustor will alter performance and pressures.
- All inputs based upon gross calorific values.
- Eclipse reserves the right to change the construction and/or configuration of our products at any time without being obliged to adjust earlier supplies accordingly.
- Plumbing of air and gas will affect accuracy of orifice readings. All information is based on generally acceptable air and gas piping practices.

## Performance Graphs

### Ignition & Operational Zones

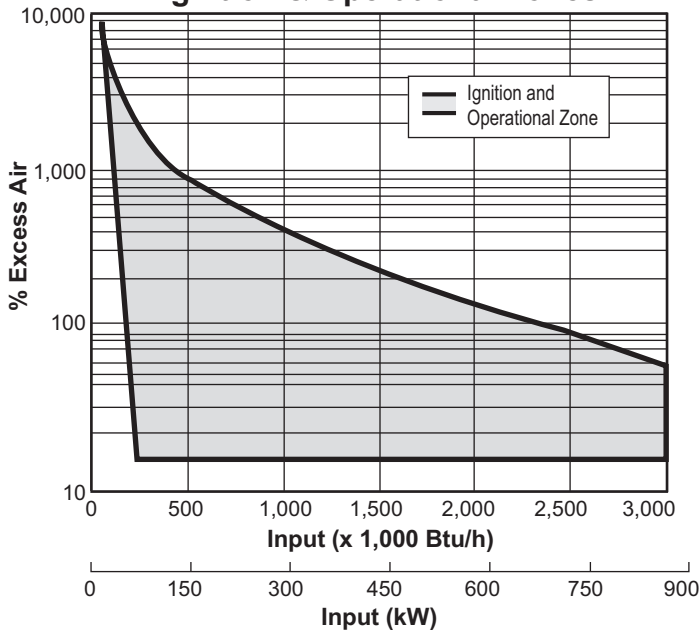

### NO<sub>x</sub> Emissions

(High Velocity Combustor)

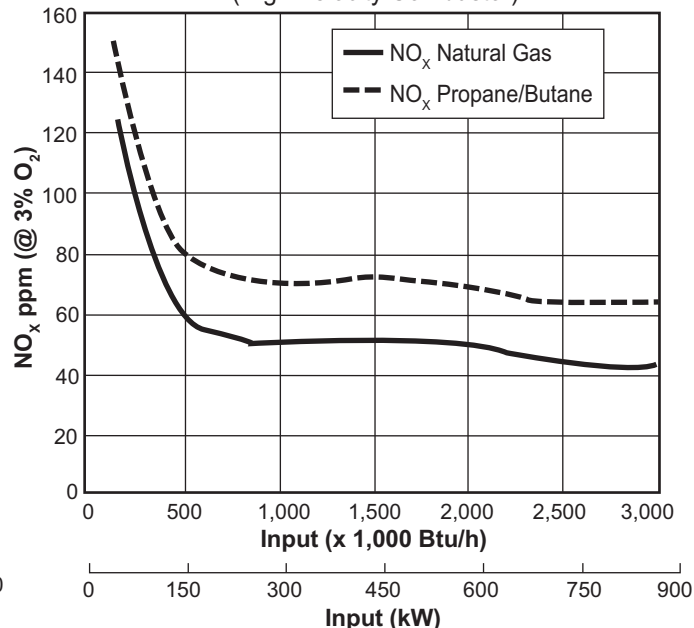

Correction factor for medium velocity combustor is 1.20. Emissions data based on on-ratio control, firing 15% excess air, corrected to 3% O<sub>2</sub>.

Emissions from the burner are influenced by:

- Fuel type
- Combustion air temperature
- Firing rate
- Chamber conditions
- Percent of excess air

For estimates of other emissions, contact Eclipse.

### Gas Orifice $\Delta P$ vs. Input

(Measured from Tap B to Tap D)

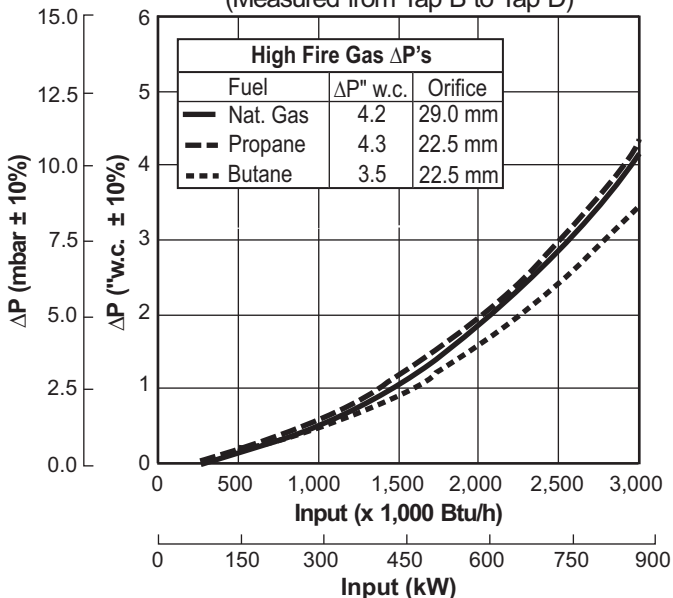

### Air Orifice $\Delta P$ vs. Input

(Measured from Tap A to Tap C)

15% Excess Air at Maximum Input

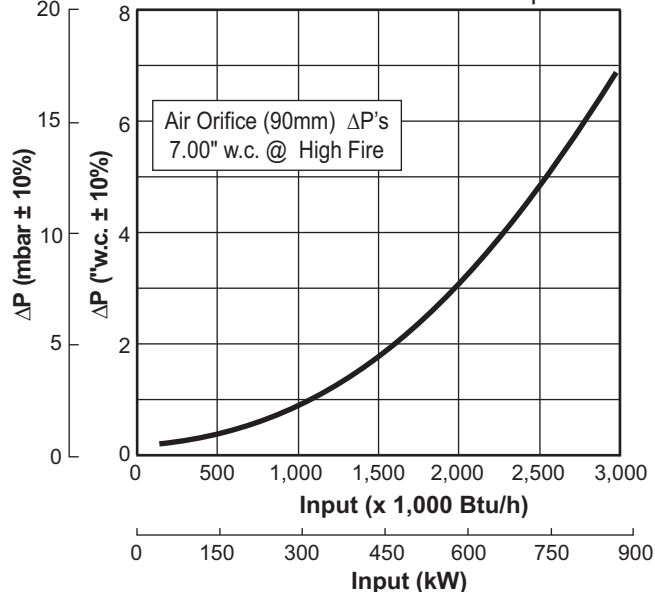

## Dimensions in inches (mm)

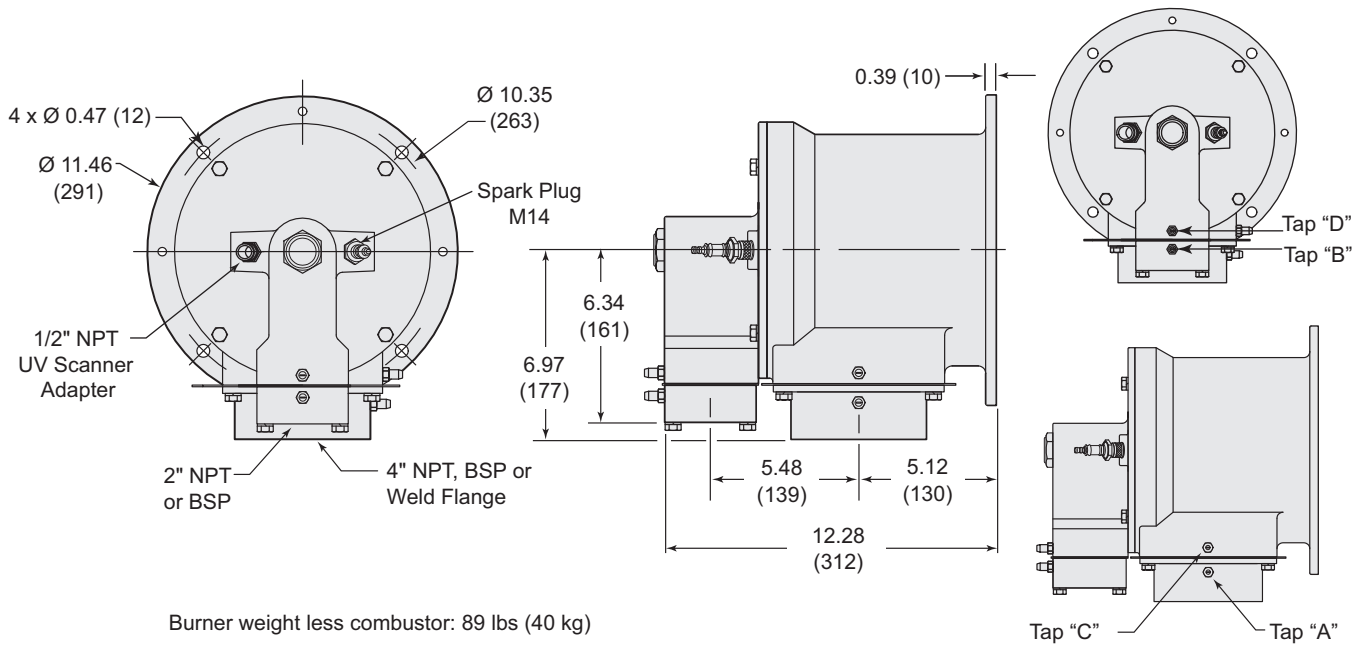

### Combustor

Exhaust Outlet Diameter: High Velocity:  $\varnothing 3.94$  (100)  
 Medium Velocity:  $\varnothing 5.31$  (135)

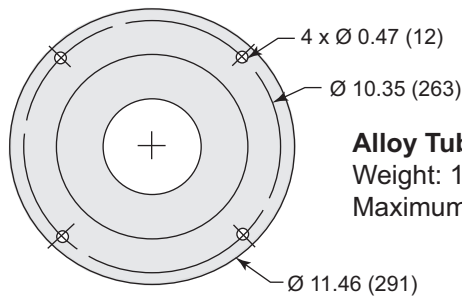
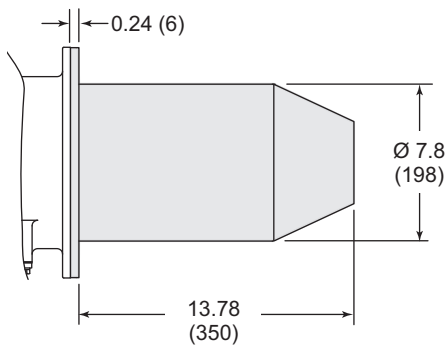

**Alloy Tube (AISI 310)**  
 Weight: 13.5 lbs (6 kg)  
 Maximum Chamber Temp: 1,750°F (950°C)

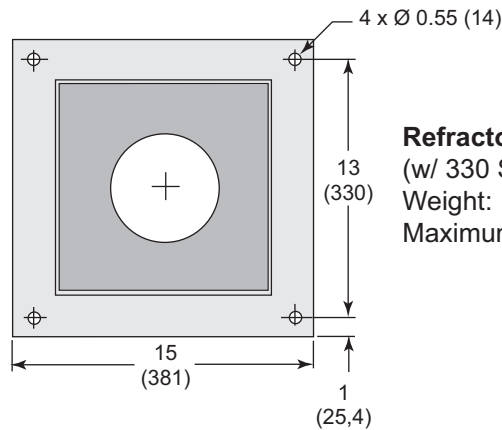
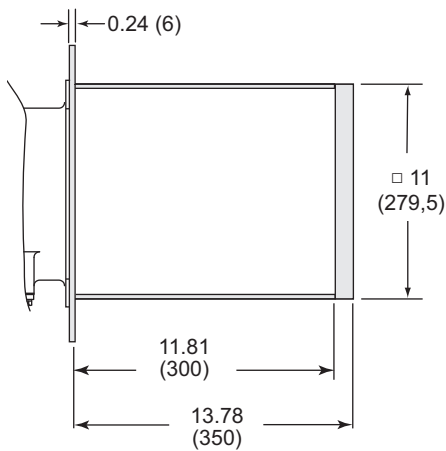

**Refractory Block**  
 (w/ 330 SS wrapper)  
 Weight: 131.4 lbs (60 kg)  
 Maximum Chamber Temp: 2,800°F (1535°C)

## Down Firing Block

