

Eclipse AirHeat Burners

AH-MA Series

Version 2.2

Parameter	Description
Maximum Input, Btu/h/ft (kW/m)	1,200,000 (1,153.85)
Combustion Air Pressure Drop, "w.c. (mbar)	0.2 to 1.4 (0.5 to 3.5)
Pilot	Interruptible pilot for natural gas, propane or butane
Integral Pilot Capacities, Btu/h (kW)	20,000 (5.9)
Burner Bodies	Standard Aluminum Low Pressure Aluminum ¹ Standard Cast Iron Corrosion Resistant, EN Plated Cast Iron Low Pressure Cast Iron ¹
Burner Section Sizes	6" (150mm) straight section 12" (300mm) straight section 12" (300mm) straight section with back inlet 12" (300mm) straight section with pilot 6" (150mm) by 12" (300mm) tee section 6" (150mm) by 12" (300mm) tee section with pilot 12" (300mm) by 12" (300mm) cross section
Maximum Upstream Air Temperature, °F (°C)	450 (232)
Maximum Downstream Air Temperature, °F (°C)	850 (454)
Maximum Temperature Rise, °F (°C)	750 (400)
Pipe Threads	NPT or BSP
Flame Detection ²	Flame rod or UV scanner
Ignition (6kVAC transformer) ³	Direct Spark Ignition Spark Ignited Pilot
Minimum Inlet Air Oxygen	18%
Fuels <i>For any other mixed gas, contact Eclipse, Inc.</i>	Natural Gas, Propane, Butane
Approvals	

¹ For use with Natural Gas only.

² When using UV scanners, Eclipse recommends a flame monitoring system that terminates the ignition spark at the end of the trial for ignition period not when it "sees" flame. Eclipse recommends that flame supervision is fitted at both ends of the burner when the flame travels more than 10 ft.

³ Direct spark ignition can be used on bumps up to 3.0 ft (1 m) long and up to 60% capacity.

- All information is based on laboratory testing. Different chamber conditions may affect the data.
- All inputs based upon gross calorific values and standard conditions; 1 atmosphere, 70°F (21°C). Contact Eclipse, Inc. for performance data above ambient temperature.
- Eclipse reserves the right to change the construction and/or configuration of our products at any time without being obliged to adjust earlier supplies accordingly.

Operating Range and Duct Pressure Measurement

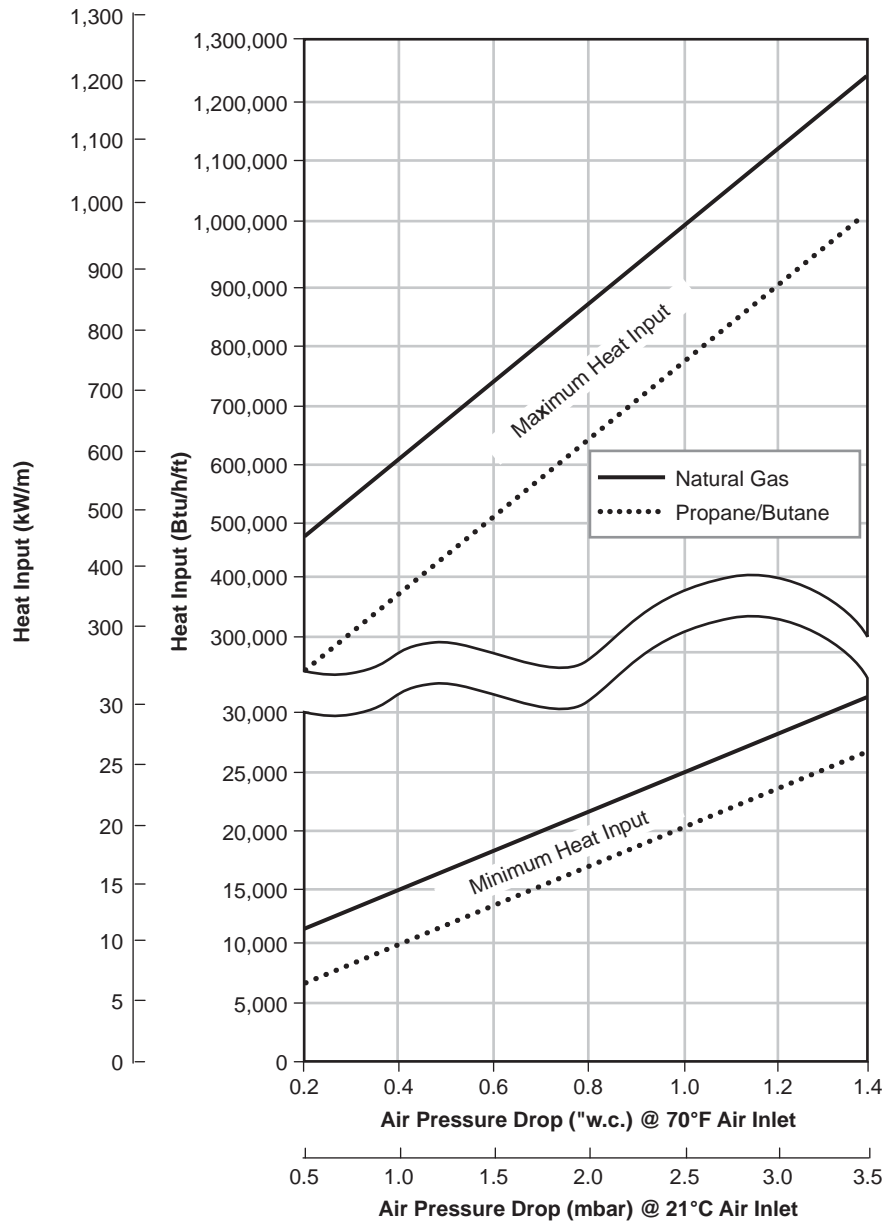

Inlet Air Temperature Correction

Air Pressure Drop @ Air Temp. = Air Pressure Drop from "Operating Range" Chart x Correction Factor										
Air Inlet Temp., °F(°C)	0 (-18)	30 (-1)	70 (21)	150 (66)	200 (93)	250 (121)	300 (149)	350 (177)	400 (204)	450 (232)
Correction Factor	0.87	0.92	1.00	1.15	1.25	1.34	1.43	1.53	1.62	1.72

Air Velocity Calculation

Imperial units:

$$\text{Air Velocity (fpm)} = 1096.2 \sqrt{\frac{\text{Air Pressure Drop (\"w.c.)}}{\text{Air Density (lbs/ft}^3\text{)}}}$$

Metric units:

$$\text{Air Velocity (m/s)} = 4.43 \sqrt{\frac{\text{Air Pressure Drop (mm w.c.)}}{\text{Air Density (kg/m}^2\text{)}}}$$

Differential Pressure Measurement and Gas Pressure Drops

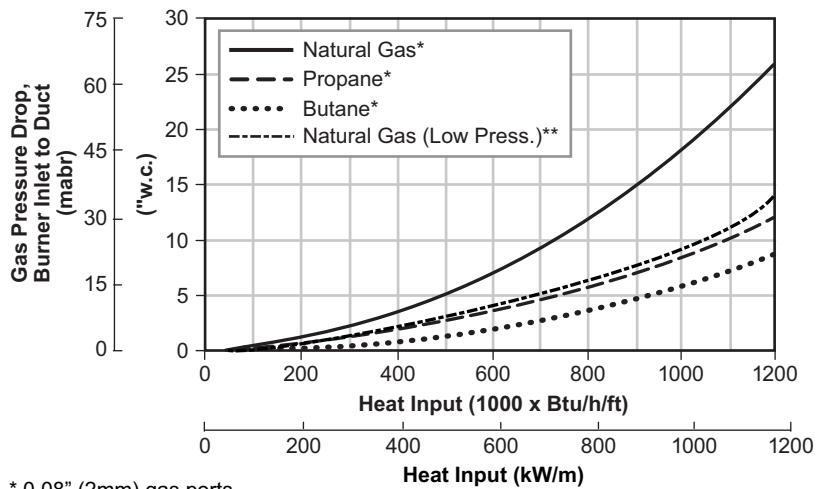
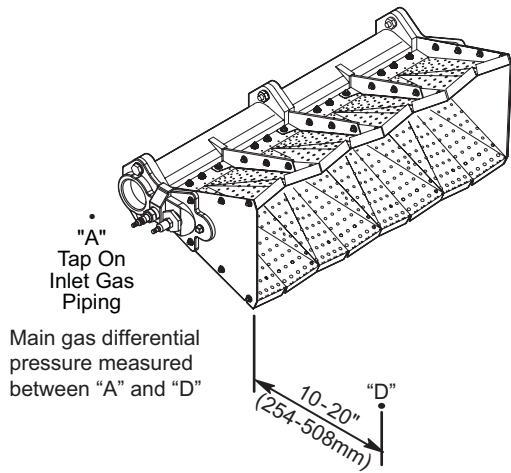

* 0.08" (2mm) gas ports.
** 0.09" (2.4mm) gas ports

Flame Lengths

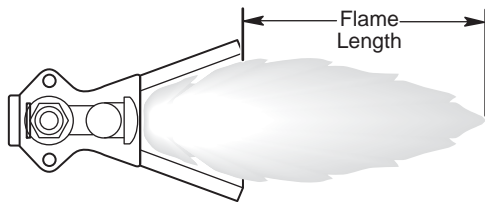

Note:
Flame length may vary slightly from these values depending on actual fuel, air handling system, duct configurations and profile plates uses.

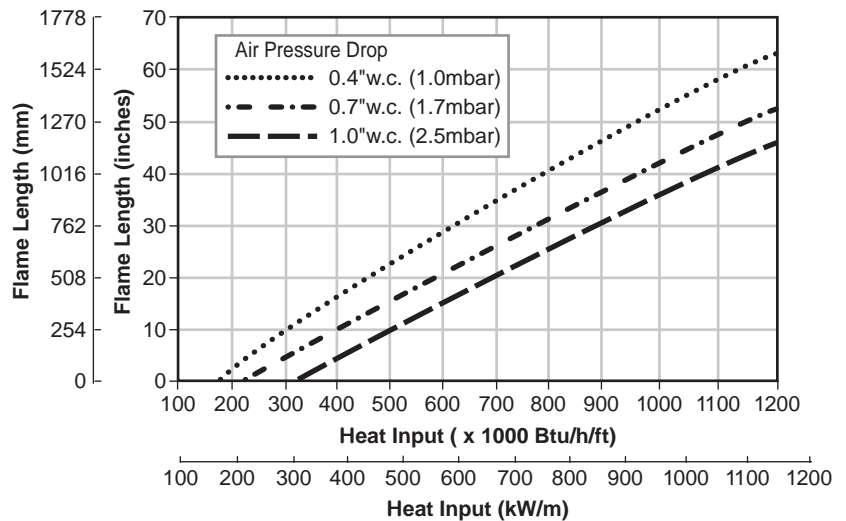

Emissions Data

